

4

3

2

1

ZONE	REV.	REVISION DESCRIPTION	ECN NO.	DATE
C1	E	"UNPLATED" WAS "UPLATED"; PD	ECN0045915	14-OCT-2008

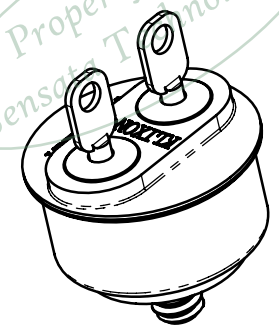
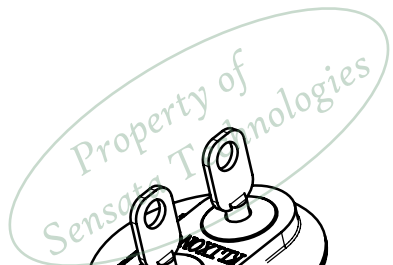

**CONFIGURATION 1**

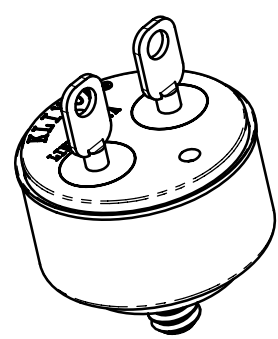

**CONFIGURATION 2**

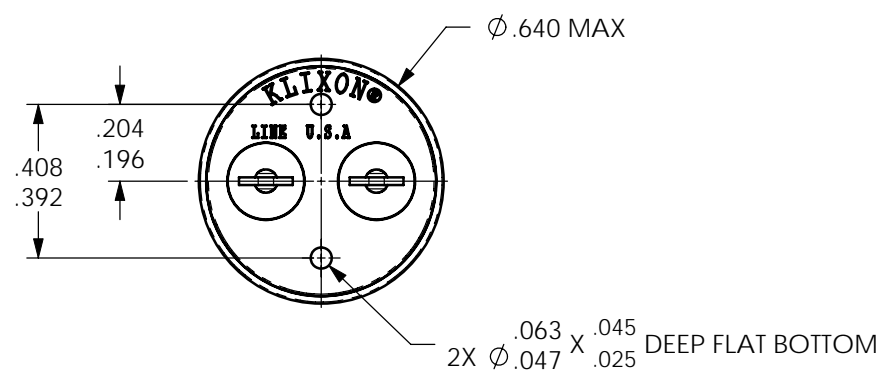
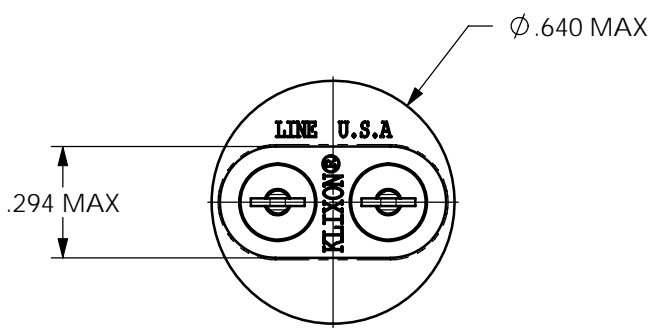

MATERIAL:  
 CONFIGURATION 1: COPPER-NICKEL PLATED CARBON STEEL  
 CONFIGURATION 2: UNPLATED 304L STAINLESS STEEL

DIELECTRIC STRENGTH:  
 TERMINAL TO CASE, 1250VAC, FOR 1 MINUTE

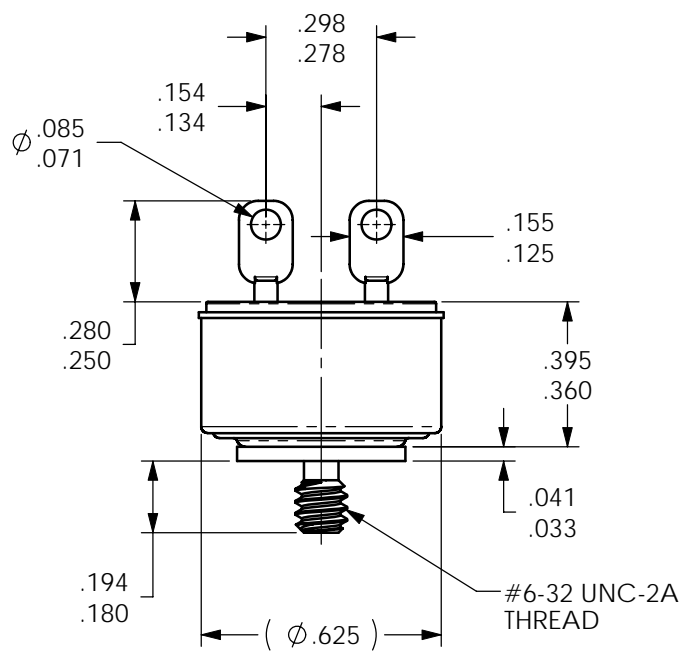
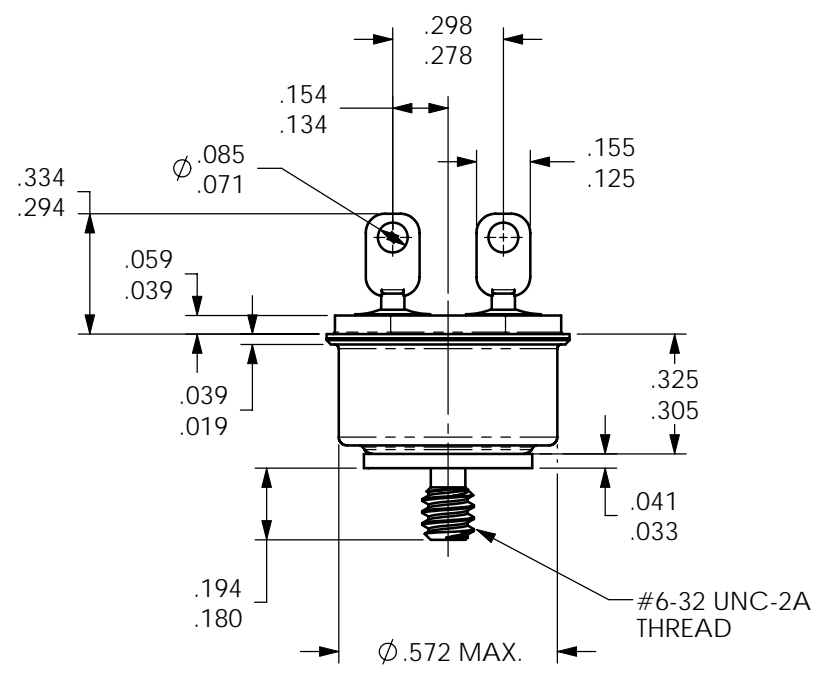

FOR REFERENCE ONLY, CHECK LATEST REVISION BEFORE USE. PARTS MADE TO THIS PRINT MUST CONFORM TO E9898 REV. E		 529 PLEASANT STREET P.O. BOX 2964 ATTLEBORO, MA 02703	TITLE <b>4344-13 THERMOSTAT SPST AUTO RESET SEALED ENVELOPE DRAWING</b>
DRAWN <b>C. FLEURANT</b> DATE 26-OCT-1995	NEITHER THIS PRINT NOR THE INFORMATION CONTAINED HEREON IS TO BE USED AGAINST THE INTERESTS OF SENSATA TECHNOLOGIES OR AGAINST THE INTERESTS OF ANY OF ITS AFFILIATED COMPANIES OR WHOLLY OWNED SUBSIDIARIES		
ENGINEER <b>S. MARQUIS</b> DATE 26-OCT-1995	UNLESS OTHERWISE SPECIFIED DIMENSIONS ARE IN INCHES TOLERANCES DECIMALS                  ANGLES	SCALE 2:1   SOLIDWORKS   SHEET 1 OF 1	
APPROVED	THIRD ANGLE PROJECTION	SIZE <b>B</b>	
DATE	DO NOT SCALE DRAWING	DEVICE: 4344	PROJECT: 256A

4

3

2

1